

# IDEAL VT100WK

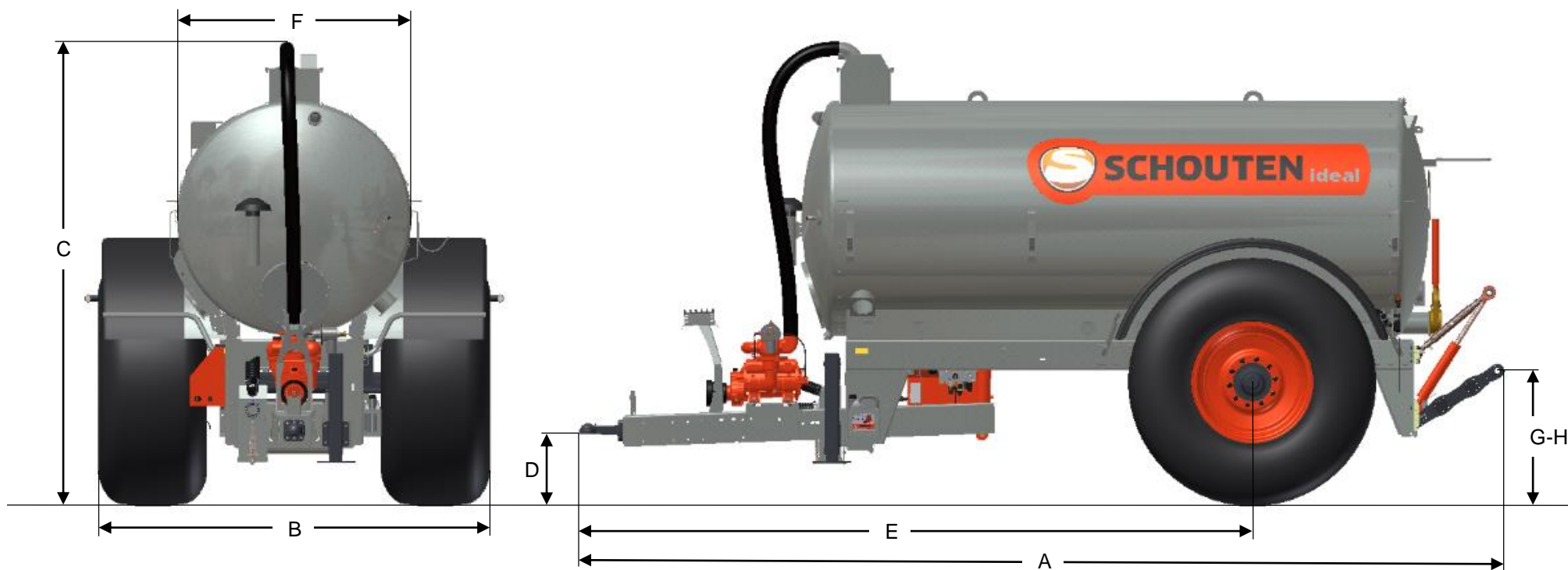

## AFMETINGEN

A	LENGTE	6612 MM	E	AFSTAND TREKOOG – WIELAS	4816 MM
B	BREEDTE	2845 MM	F	TANKDIAMETER	1700 MM
C	HOOGTE	3400 MM	G	HOOGTE HEF MIN.	235 MM
D	AANSPANHOOGTE	400-700 MM	H	HOOGTE HEF MAX.	990 MM

# IDEAL VT100WK

## MACHINE INFORMATIE

TYPE	VT100WK
GEWICHT	3120 KG
TANKAFMETING	Ø1700X4040 MM
TANKINHOUD	10.000 LTR
NIVEAU AANDUIDING	VLOTTERWIJZER
ONDERSTEL	ENKELAS
TYPE WIELAS	BPW GEREMD □150MM
DRAAGVERMOGEN WIELAS	15.000 KG
BANDEN	800/60R32

STEUNPOOT	HYDR. DW
VACUUMPOMP	B&P MEC11000
CAPACITEIT VACUUMPOMP	11.137 L/MIN
AANDRIJVING VACUUMPOMP	PTO 540/1000RPM
VOCHTVANGER CAPACITEIT	15.500 L/MIN
HEFMOGELIJKHEDEN	GRAS – BOUWLAND
HEFCAPACITEIT	3500 KG
AANSPANNING HEFINRICHTING	4-PUNTS CAT III

## OPTIES

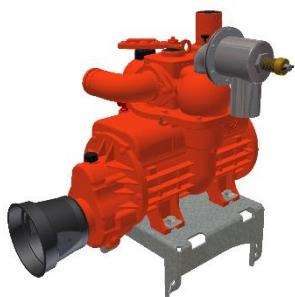

B&P MEC13500

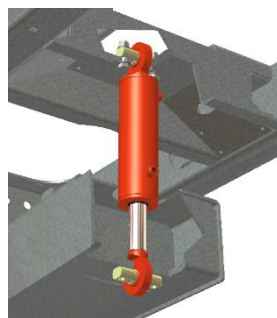

GEVEERDE DISSEL

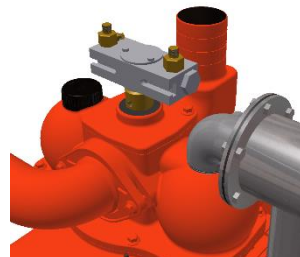

HYDR. POMPSCHAKELING

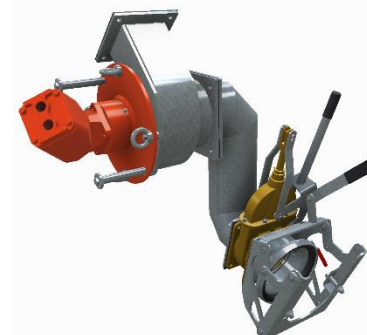

TURBO-MASTER 8-6



ZUIGARM 8" BOLKKOP